

FILED FOR RECORD: 2-6 19 84 at 4:00 o'clock P M
 DULY RECORDED: 2-7 19 84 at 9:00 o'clock A M
 INSTRUMENT NO. --- GRACE BOSTICK, TYLER CO. CLK.
 BY: Jean Phillips Deputy
 JEAN PHILLIPS

TYLER COUNTY COMMISSIONER'S COURT
 SPECIAL MEETING
 JANUARY 30, 1984---10:00 A. M.

VOL 008 PAGE 942

A Special Meeting of the Commissioner's Court met on Monday, January 30, 1984, at 10:00 A. M. All members being present. The meeting was opened with prayer by Commissioner Pct. #4, James R. Jordan.

A motion was made by Commissioner Jordan and seconded by Commissioner Lowe to approve Tina Bump as a new Deputy in the District Clerk's office, as requested by District Clerk Patricia Brown. All voted yes and none no. See Attached.

A motion was made by Commissioner Lowe and seconded by Commissioner Mahan to set the terms of County Court for the year 1984 as the months of January, April, July and October. All voted yes and none no.

A motion was made by Commissioner Lowe and seconded by Commissioner Mahan to reject all bids received on a new Dozer for the Solid Waste Site, as the old machine has been repaired and is now in use, also, to allow Commissioner Lowe to consider negotiations for a new Dozer at a later date and report to Commissioner's Court when he does so. All voted yes and none no. Bids received are as listed below:

Mustang Tractor & Equipment Co.-----	\$95,223.00
Less Trade-in-----	52,036.00
Total Bid Price-----	43,187.00
George P. Bane, Inc.-----	85,495.00
Less Trade-in-----	26,258.00
Total Bid Price-----	59,237.00

See Attached.

A motion was made by Commissioner Riley and seconded by Commissioner Jordan to accept the lowest bid received on two (2) trailers, one each for Pct. #1 and Pct. #4, submitted by Mustang Tractor and Equipment Co., Lufkin, Texas. All voted yes and none no. Bids received are listed below:

Birdwell's Welding & Machine Shop--Two (2) Trailers---	\$28,190.00
George P. Bane, Inc.--Two (2) Trailers-----	20,918.00
Mustang Tractor & Equipment Co.--Two (2) Trailers-----	20,485.00

See Attached.

A motion was made by Commissioner Riley and seconded by Commissioner Lowe to approve the appointment of Patrick O. Hardy to the office of County Attorney, replacing Joe R. Smith, who resigned effective February 1, 1984. Mr. Hardy will serve in this position until the General Election in November, 1984; also, to continue serving as Assistant to the District Attorney from both Hardin and Tyler Counties, receiving no salary from Hardin County. All voted yes and none no.

Ileen Mason appeared before Commissioner's Court to report on the work that is being done concerning the Mental Health, Mental Retardation Workshop, covering Tyler County. Also, she introduced Paul Jackson, Unit Director of Jasper and Tyler Counties; Kathy Kinnon, Service Aid Three for Tyler County; and Marty Walker, Unit Director for Jasper, Newton, and Tyler County Sheltered Workshops, and each in turn gave a brief summary of the work being done over the Counties listed. Members of Commissioner's Court praised Mrs. Mason for a job well done.

A motion was made by Commissioner Riley and seconded by Commissioner Lowe to advertise for bids on a 1981 Ford, 4Dr. Sedan, from the Sheriff's Department; with bids received to be opened on Friday, February 17, 1984, at 10:00 A. M. All voted yes and none no.

There being no further business, the meeting adjourned.

SIGNED:

Allen Starrock Allen Starrock, County Judge

Maxie Riley Maxie Riley, Comm. Pct. #1

H. K. Lowe H. K. Lowe, Comm. Pct. #2

Jerry Mahan Jerry Mahan, Comm. Pct. #3

James R. Jordan James R. Jordan, Comm. Pct. #4

ATTEST:

Grace Bostick Grace Bostick, County Clerk



NOTICE OF TIME AND PLACE OF MEETING

COMMISSIONERS COURT
TYLER COUNTY, TEXAS

THIS NOTICE POSTED IN ACCORDANCE WITH V. A. T. S. - ART. 6252-17

NOTICE is hereby given that Commissioners Court will hold it's
Special meeting on MONDAY, JANUARY 30 1984 at 10:00 A.M.
in the Commissioners Courtroom, First Floor, Tyler County Courthouse.

A G E N D A

CONSIDER OPENED

1. ~~XOPEN~~ BIDS ON DOZIER FOR DUMP.
2. OPEN BIDS ON FLAT BED TRAILER FOR PRECINCT I AND IV.
3. CONSIDER APPOINTING COUNTY ATTORNEY.
4. M.H.M.R..WORKSHOP REPORT BY ILEEN MASON.
5. SET TERMS OF COURT.
6. APPROVE TINA BUMP AS DEPUTY IN DISTRICT CLERKS OFFICE.

7- *Advertise for Bids on used car from Sheriff's office*
1/30/84 JDM

Allen Sturrock
Allen Sturrock, County Judge
Tyler County, Texas

NO. _____ TIME *8:30* AM
PM

JAN 27 1984

GRACE BOSTICK, COUNTY CLERK
TYLER COUNTY, TEXAS

Grace Bostick

NOTICE OF TIME AND PLACE OF MEETING

COMMISSIONERS COURT
TYLER COUNTY, TEXAS

THIS NOTICE POSTED IN ACCORDANCE WITH V. A. T. S. - ART. 6252-17

NOTICE is hereby given that Commissioners Court will hold it's

Special meeting on MONDAY, JANUARY 30 1984 at 10:00 A.M.

in the Commissioners Courtroom, First Floor, Tyler County Courthouse.

A G E N D A

CONSIDER OPENED

1. ~~X~~ OPEN BIDS ON DOZIER FOR DUMP.
2. OPEN BIDS ON FLAT BED TRAILER FOR PRECINCT I AND IV.
3. CONSIDER APPOINTING COUNTY ATTORNEY.
4. M.H.M.R..WORKSHOP REPORT BY ILEEN MASON.
5. SET TERMS OF COURT.
6. APPROVE TINA BUMP AS DEPUTY IN DISTRICT CLERKS OFFICE.

7- *Advertisement for Bids on used car from Sheriff's office*
1/30/84 JDM

Allen Sturrock, County Judge
Tyler County, Texas

NO. _____ TIME: 8:30 AM
PM

JAN 27 1984

GRACE BOSTICK, COUNTY CLERK

BY: *Tina Burdwell*



DEPUTATION

VOL 008 PAGE 944

THE STATE OF TEXAS

COUNTY OF TYLER

I, Patricia Brown

District Clerk of the County of Tyler, and State of Texas, having full confidence in Tina Bump of said County and State, do hereby, with the consent of the Commissioners' Court of Tyler County, Texas, nominate and

appoint her, the said Tina Bump my true and lawful deputy, in my name, place and stead, to do and perform any and all acts and things pertaining to the office of said

District Clerk of said County and State, hereby ratifying and confirming any and all such acts and things lawfully done in the premises by virtue hereof.

Witness my hand, this 25th day of January A. D. 19 84

Patricia Brown

District Clerk of Tyler County, Texas.

THE STATE OF TEXAS

COUNTY OF TYLER

Before Me, the undersigned authority, in and for

Tyler County, Texas, on this day personally appeared Patricia Brown

known to me to be the person whose name is subscribed to the foregoing deputation and acknowledged to me that he executed the same for the purposes and considerations therein expressed.

Given under my hand and seal of office at Woodville, Texas, this 25th day of January A. D. 19 84

Notary Public in and for Tyler County, Texas

Delores Wigley

OATH OF OFFICE

I, Tina Bump, do solemnly swear (or affirm), that I will

faithfully excute the duties of the office of Tyler County District Clerk Deputy of the State of Texas, and will to the best of my ability preserve, protect, and defend the Constitution and laws of the United States and of this State; and I furthermore solemnly swear (or affirm), that I have not directly nor indirectly paid, offered, or promised to pay, contributed, nor promised to contribute any money, or valuable thing, or promised any public office or employment, as a reward to secure my appointment or the confirmation thereof. So help me God.

Subscribed and sworn to before me, this 25th day of January A. D. 19 84

Delores Wigley

Notary Public in and for Tyler County, Texas

*NOTE: It is understood that in taking the Official Oath by officers in appointive positions, this phrase implies "appointment" rather than "election."

ORDER AUTHORIZING APPOINTMENT OF DEPUTY

In Commissioners' Court of Tyler County, Texas.

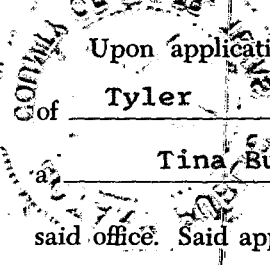

Upon application duly presented, it is ordered by the Court that Patricia Brown, District Clerk

of Tyler County, Texas, be and he is hereby authorized to appoint and deputize Tina Bump for Deputy District Clerk

said office. Said appointment to date from the 25th day of January 19 84, and to continue in effect until revoked by said officer or be otherwise terminated; ~~and the compensation to be~~

~~paid said deputy is hereby fixed at the sum of _____ Dollars, per annum, payable solely from the fees of said office.~~

Entered 7th day of February 19 84. Recorded in Minute Book 8 Page 942



<p>NO. _____</p> <p>585</p> <p>DEPUTATION</p> <p>OF</p> <p>TINA BUMP</p>	<p>Filed for record the <u>30th</u> day of <u>January</u> <u>19 84</u> at <u>10:00</u> o'clock <u>A</u> M., and recorded <u>7th</u> day of <u>February</u> <u>19 84</u>, in Book <u>8</u> page <u>942</u> of the records of deputations of <u>Tyler</u> County <u>W. B. Smith</u> Clerk County Court <u>Tyler</u> County, Texas. By _____, Deputy.</p>
--	--



Mustang TRACTOR & EQUIPMENT CO.

HOUSTON, TEXAS 77040 12800 Northwest Freeway (713) 460-2000



BEAUMONT, TEXAS 77706
7990 Eastex Freeway
(713) 892-8412

EL CAMPO, TEXAS 77437
Highway 71 (North)
(713) 543-3389

LUFKIN, TEXAS 75901
Highway 69 (S.E.)
(713) 639-5551

BRYAN, TEXAS 77801
3605 S. College St.
(713) 846-7761

VOL 008 PAGE 946

QUOTATION

TO
Commissioner's Court
Tyler County
Woodville, Texas 75979

QUOTATION NO. S84-23

DATE January 19, 1984

CUSTOMER INQUIRY NO.

Gentlemen:

IMPORTANT: WHEN ORDERING, PLEASE MENTION ABOVE QUOTATION NUMBER AND DATE.

QUAN.	DESCRIPTION	UNIT PRICE	EXTENSION
	We are pleased to submit the following for your consideration:		
1	New Caterpillar D5 tractor, Series B. Includes diesel engine with 24-volt direct electric starting, 35 ampere alternator, blower fan, fuel priming pump, rain cap, muffler, 6-roller track frame, retrieval hitch, 20-inch grouser-sealed and lubricated tracks (39-section), large idlers, hydraulic track adjusters, horn, back-up alarm, ROPS canopy and mounting, rearview mirror, seat belt, decelerator, upper engine guards, hinged radiator guard, and angle blade with 2 tilt cylinders.		
	Price		\$95,223.00
	Less trade-in of your John Deere 750		52,036.00
	Price after trade-in		\$43,187.00
	Option: Should you elect to purchase a standard 5S with tilt in lieu of 5 angle with tilt, DEDUCT		686.00
	Delivery: From stock, subject to prior sale.		
	We appreciate the opportunity of quoting on your equipment requirements and hope we may be favored with your order.		
	APPLICABLE WARRANTY(S): See Attached PRICES ARE F.O.B.: Woodville, Texas		

THIS QUOTATION SHALL TERMINATE UNLESS MUSTANG RECEIVES WRITTEN ACCEPTANCE WITHIN 30 DAYS HEREOF.

ACCEPTED THIS DAY OF _____, 19____

MUSTANG TRACTOR & EQUIPMENT COMPANY

By _____
(If signing for a corporation or partnership, include name of customer and title of person signing.)

By James Lindsay Area Manager
(TITLE)

THIS QUOTATION IS SUBJECT TO THE TERMS AND CONDITIONS CONTAINED ON THE REVERSE SIDE HEREOF, SAME BEING INCORPORATED HEREIN BY REFERENCE.

1. Price, Terms of Payment. All prices are exclusive of sales and any other applicable taxes. Unless terms acceptable to Mustang Tractor & Equipment Company ("Mustang") are agreed to in advance, all prices are payable in full prior to delivery. Orders are placed at manufacturer's current list price. In the event of price changes by manufacturer, the price prevailing at time of delivery will be paid by purchaser.

2. Product Warranty, Disclaimer and Limitation. The only warranties, if any, applicable to any item of machinery, equipment or other personal property subject hereto are identified on the reverse side hereof.

2.1. New Products. Mustang will not make any warranties, express or implied, regarding any new item of machinery, equipment or other personal property subject hereto, and Mustang DISCLAIMS ALL WARRANTIES, EXPRESS OR IMPLIED, INCLUDING, BUT NOT LIMITED TO, ALL IMPLIED WARRANTIES OF MERCHANTABILITY AND OF FITNESS FOR A PARTICULAR PURPOSE with respect to each such item. Customer's sole and exclusive remedy, if any, for defects in materials or workmanship with respect to any new item of machinery, equipment or other personal property subject hereto shall be against the manufacturer or manufacturers thereof pursuant to the express, written warranty, if any, extended by such manufacturer or manufacturers with respect to such products and described on the reverse side hereof. If any such express, written warranty is applicable, a copy thereof will be furnished upon request.

2.2. Used Products. Mustang will not make any warranties, express or implied, regarding any used item of machinery, equipment or other personal property and Mustang has expressly DISCLAIMED ALL WARRANTIES, EXPRESS OR IMPLIED, INCLUDING, BUT NOT LIMITED TO, ALL IMPLIED WARRANTIES OF MERCHANTABILITY AND OF FITNESS FOR A PARTICULAR PURPOSE regarding any such used item except for the express warranties specifically described on the reverse side hereof, if any. An explanation of each warranty offered by Mustang is set forth below. ONLY THE WARRANTY DESCRIBED ON THE REVERSE SIDE HEREOF WILL BE APPLICABLE TO THE SALE BY MUSTANG OF THE PRODUCTS DESCRIBED HEREIN.

A. BONDED BUY — If the applicable warranty is "Bonded Buy", the product described on the reverse side hereof will be warranted against defective material or workmanship for a period of 60 days from purchase date. No charge will be made for parts or labor if the defect occurs and Mustang is notified in writing during the 60 day period from purchase date.

B. PREMIUM BUY — If the applicable warranty is "Premium Buy", the product described on the reverse side hereof will be warranted against defective material or workmanship for a period of 30 days from purchase date. No charge will be made for parts or labor if the defect occurs and Mustang is notified in writing during the 30 day period from purchase date.

C. CERTIFIED BUY — If the applicable warranty is "Certified Buy", the product described on the reverse side hereof will be warranted against defective material or workmanship for a period of 30 days from purchase date. If defects do exist Mustang will pay ONE-HALF of cost for parts and labor if Mustang is notified in writing during the 30 day period from purchase date.

D. BUY AND TRY — If the applicable warranty is "Buy and Try" and the product does not meet purchaser's satisfaction, it may be returned within three days of purchase for a full refund. THERE ARE NO OTHER IMPLIED OR EXPRESS WARRANTIES.

E. "AS IS" — If the applicable warranty is "As Is", no IMPLIED OR EXPRESS WARRANTIES of any kind whatsoever will be applicable to product purchased.

The parties agree that the Customer's SOLE AND EXCLUSIVE REMEDY against Mustang under BONDED, PREMIUM or CERTIFIED BUYS will be for the repair or replacement of defective parts as provided in the warranty or condition selected. Repair or Replacement shall be at Mustang's discretion and AT MUSTANG'S REGULAR PLACE OF BUSINESS, during normal business hours. Customer agrees that no other remedy (including, but not limited to claims for INCIDENTAL, SPECIAL OR CONSEQUENTIAL DAMAGES, FOR ANY CAUSE WHATSOEVER, or INJURY TO PERSONS OR PROPERTY, OR ANY OTHER CONSEQUENTIAL, ECONOMIC OR SPECIAL INCIDENTAL LOSS) shall be available to him.

Customer acknowledges and agrees that this quotation contains all agreements between Customer and Mustang and they are hereby accepted by Customer. Customer further agrees and acknowledges that no verbal contracts, agreements or warranties other than what is written in this quotation have been received or given, and signature on this quotation by Customer acknowledges this fact.

3. Force Majeure. This quotation, when accepted by Customer, shall become a binding contract but Mustang's obligation to deliver shall be conditioned upon and subject to strikes, walkouts, accidents, fire, delays in manufacturer transportation, acts of God, and embargoes or Governmental action or any other causes beyond the control of Mustang whether the same as or different from the matters and things hereinabove specifically enumerated, and any of such causes shall absolutely absolve Mustang from any liability to Customer, under the terms hereof. Upon acceptance, Customer, shall be obligated to pay the purchase price applicable to the products reflected on the reverse side hereof in accordance with the terms hereof and of any other documents now, heretofore or hereafter executed to evidence such obligation.

4. Security Interest. If the product(s) is not paid for in full in cash at the time of delivery, Mustang will retain and Customer hereby grants to Mustang a security interest in such product(s) within the meaning of the Uniform Commercial Code together with all and any substitutions, additions, or accretions to such product(s), and in any and all proceeds from the sale, exchange or disposal thereof to secure payment of the purchase price of such product(s). Customer, prior to or after delivery, specifically agrees to enter into and execute a financing statement, or statements, and an additional security agreement setting forth the terms and conditions of the Agreement between the parties in relation to the security interest of Mustang. Customer further appoints Mustang as its attorney-in-fact to execute any such financing statement or security agreement in the place and stead of Customer. In the event Customer fails to execute any such financing statement or security agreement upon request by Mustang, the entire balance of the purchase price shall at Mustang's option become due and payable and Mustang shall have all remedies available to it provided for and set out in the Uniform Commercial Code. Customer also agrees to execute and deliver to Mustang any notes or other evidences of indebtedness that may be required by Mustang. However, any note taken herewith shall be evidence of Customer's obligation to pay the unpaid time balance only and is not to be considered or construed to be payment for the product(s). **LATE OR DEFERRED PAYMENT SHALL BEAR INTEREST AT THE HIGHEST CONTRACT RATE PERMITTED BY LAW.**

5. Shipment. Mustang's responsibility for shipment will cease upon delivery to a transportation company and any claims for shortages, delays or damages occurring thereafter shall be made by Customer directly to the transportation company. Any claims which Customer may be entitled to make against Mustang for shortages and shipments shall be made within fifteen (15) days after receipt of shipment.

6. Enforceability, Entire Agreement. Customer agrees that this quotation, upon acceptance by Customer, shall not be countermanded by him and that when it is accepted (and until the execution and delivery of the contract or contracts and note or notes required to consummate the sale of this above specified) it will, together with any security agreement, promissory note or other evidence of indebtedness executed by Customer subsequently hereto, constitute the entire agreement between the parties relative to this transaction. Customer further agrees that Mustang is not bound by any representations or agreements made by any agent or employee of Mustang relative to this transaction unless specifically embodied herein.

7. Indemnity. Customer further agrees to indemnify and save harmless Mustang from all loss, damage, expense and penalty arising from any action on account of any injury to person or property of any character whatsoever occasioned by the operation, handling or transportation of any of the product(s) covered by this quotation and while the product(s) is in the possession or under the custody and control of Customer.

8. Place of Payment, Venue. In consideration of the sale of the product(s) by Mustang, Customer agrees to pay Mustang for such product(s) at Mustang's principal office in Houston, Harris County, Texas.

9. Attorney's Fees. In the event any action either to collect payment or enforce the terms and provisions of this quotation becomes necessary, Customer agrees to pay reasonable attorney's fees to Mustang should this matter be placed in the hands of an attorney for collection.

10. Miscellaneous. This quotation shall be interpreted and construed in accordance with the laws of the State of Texas. Invalidity of any portion of this quotation shall not affect the validity or enforceability of the remainder of the terms and conditions hereof, and the parties hereby agree that this quotation shall be construed as if such invalid provision had not been inserted.

11. Termination of Quotation. This quotation shall terminate unless Mustang receives written acceptance hereof within the period set forth on the reverse side hereof. Such written acceptance must refer to the quotation number and date of this quotation.

12. Cancellation. In the event Seller consents in writing to cancellation, Buyer shall pay Seller, at Seller's option, the following as liquidated damages:

- Invoice price of all goods which have been identified to the contract, whether such goods have been delivered to Buyer or not.
- Actual costs incurred by Seller for goods not completed which are allocable to the balance of the contract, including the cost of discharging Seller's liabilities which are so applicable and the costs of materials on hand which were acquired or produced in connection with partially finished work and materials.
- A reasonable allowance for profit in connection with goods called for under the contract, but with respect to which production has not yet begun at the time of cancellation.
- Reasonable costs incurred by Seller, including accountants' and attorneys' fees, if any, in making any termination settlement hereunder.



CATERPILLAR

D5B Track-type Tractor

Summary of features

- **Operator comfort** is provided by the optional semi-modular, sound-suppressed ROPS cab, non-glare dashboard, two-way adjustable seat, single lever dozer control with adjustable lever, and combined hand-lever steering and braking.
- **Sealed and Lubricated Track** greatly reduces internal pin and bushing wear for lower undercarriage maintenance costs.
- **Oil cooled steering clutches and brakes** . . . increase component life and improve reliability.
- **Cat 3306 diesel Engine** . . . 638 cu. in. (10.5 litres) displacement . . . with individual adjustment-free fuel pumps and valves.
- **Choice of planetary power shift or direct drive transmissions.**
- **Easy maintenance** with spin-on fuel filter, split master link, hydraulic track adjusters, optional tilt cab. Steering clutches and brakes are removable as a unit.
- **CAT PLUS** . . . from your Caterpillar Dealer . . . the most comprehensive, total customer support system in the industry.

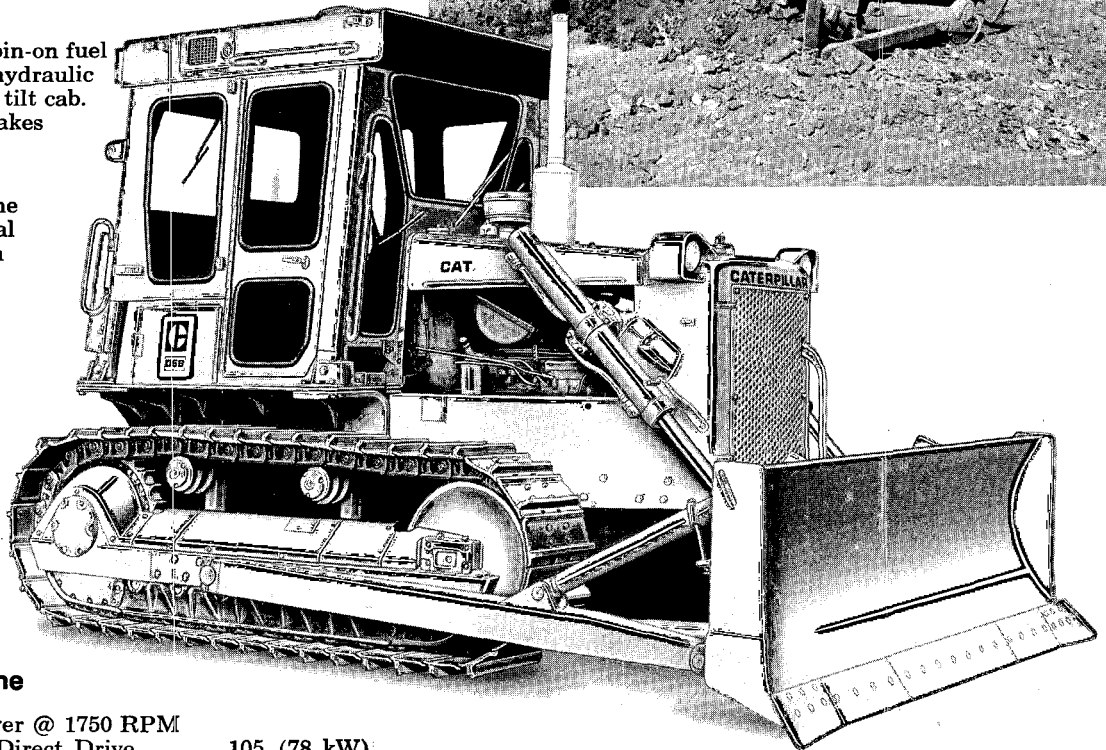

Caterpillar Engine

Flywheel horsepower @ 1750 RPM
 Power shift and Direct Drive 105 (78 kW)
 (Kilowatts (kW) is the International System of Units equivalent of horsepower.)

The net power at the flywheel of the vehicle engine operating under SAE conditions: 85° F (29° C) and 29.38" Hg (995 mbar), using 35 API gravity fuel oil at 60° F (15.6° C). Standard engine accessories, including blower fan, fuel priming pump, filter, dry-type air cleaner, and muffler. Engine will maintain specified power up to 5,000 ft. (1500 m) altitude.

Caterpillar 4-stroke-cycle 3306 diesel with 6 cylinders, 4.75" (121 mm) bore, 6.0" (152 mm) stroke, and 638 cu. in. (10.5 litres) displacement.

Precombustion chamber fuel system with individual adjustment-free injection pumps and valves.

Cam-ground and tapered aluminum alloy pistons with 3-ring design. Steel-backed aluminum bearings, Hi-Electro hardened crankshaft journals. Pressure lubrication with full-flow filtered oil. Dry-type air cleaner with primary and safety elements.

Two 24-volt direct electric starting systems – standard or low temperature. Glow plugs for preheating precombustion chambers are included with both.

Shown with optional ROPS sound-suppressed cab (ROPS canopy is standard in U.S.A.), lights, track roller guards, end guiding guards, hydraulic control, and 5S Bulldozer.



transmission

Power shift:

Planetary power shift with 12.25" (311 mm) diameter, high-torque-capacity oil clutches. Special valve permits unrestricted speed and direction changes under full load. Three speeds forward, three reverse.

Single-stage torque converter directly connects to the transmission. Oil-to-air heat exchangers cool the torque converter oil.

Gear	Forward Speed		Reverse Speed	
	MPH	(km/h)	MPH	(km/h)
1	2.2	(3.5)	2.6	(4.2)
2	3.8	(6.1)	4.6	(7.4)
3	6.3	(10.1)	7.6	(12.2)

D5B

Track-type Tractor

transmission (continued)

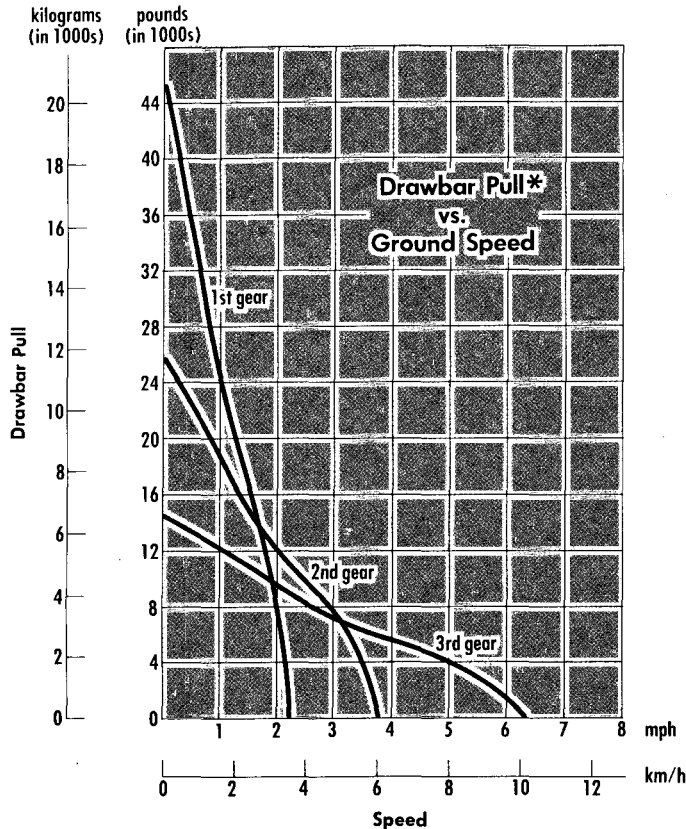

* Usable pull will depend upon traction and weight of the tractor.

Direct drive:

Sliding gear-type transmission with fast forward-reverse shift. Filtered, full-pressure lubrication.

Flywheel clutch has two metallic-faced plates with over-center engagement. Clutch lubricated and cooled by pressure-circulated oil. Connected to the transmission by double universal joint.

Direct drive speeds and drawbar pulls:

Gear	Forward		Reverse		Drawbar Pull Forward*			
	MPH (km/h)	MPH (km/h)	MPH (km/h)	MPH (km/h)	At Rated RPM		Maximum at Lug	
					Lb.	(kg)	Lb.	(kg)
1	1.7 (2.7)	2.1 (3.4)	19,340 (8770)	24,540 (11 130)				
2	2.6 (4.2)	3.3 (5.3)	12,130 (5500)	15,530 (7040)				
3	3.6 (5.8)	4.6 (7.4)	8,270 (3750)	10,700 (4850)				
4	5.0 (8.0)	6.3 (10.1)	5,610 (2540)	7,380 (3350)				
5	6.9 (11.1)	—	3,660 (1660)	4,950 (2250)				

Optional transmission:

1	2.3 (3.7)	3.0 (4.8)	13,910 (6310)	17,760 (8060)
2	2.7 (4.3)	3.5 (5.6)	11,690 (5300)	14,980 (6790)
3	3.3 (5.3)	4.2 (6.8)	9,390 (4260)	12,100 (5490)
4	3.7 (6.0)	4.8 (7.7)	8,000 (3630)	10,370 (4700)
5	4.2 (6.8)	—	6,900 (3130)	9,000 (4080)
6	5.1 (8.2)	—	5,390 (2440)	7,100 (3220)

* Usable pull will depend upon traction and weight of the tractor.



steering

Hydraulically actuated, multiple-disc oil cooled steering clutches are held in engagement by springs and disengaged hydraulically. The bronze disc assemblies provide high load carrying capability, long life and require no adjustment. Hydraulically boosted, oil cooled, contracting band brakes. Clutch and brake assemblies may be serviced as a unit.

Hand levers combine steering clutch disengagement and braking in one control. Brake pedals are retained for operators who prefer them. Mechanical parking brake.



final drives

Crown-shaved, single-reduction final drive gears. Duo-Cone® Floating Ring Seals. Sprockets with bolt-on, replaceable rim segments.



track roller frame

Reinforced box-section construction. Inside-mounted carrier rollers. Lifetime-Lubricated rollers and idlers. Number of rollers (each side) 6 Oscillation at front idler 11.0" (279 mm)



Sealed and Lubricated Track

Sealed and Lubricated Track surrounds the track pin with lubricant to greatly reduce internal bushing wear. Lubricant held by a sealing arrangement consisting of a polyurethane seal, a rubber load ring and a thrust ring. Hydraulic track adjusters and split master link standard.

Number of shoes (each side) 39
Width of standard shoe 16" (406 mm)
Length of track on ground 87" (2210 mm)
Ground contact area with
16" (406 m) shoes 2,800 sq. in. (1.81 m²)
Grouser height (from ground
face of shoe) 2.25" (57 mm)



hydraulic controls

Four optional systems are available. Complete system consists of pump, tank, filter, valves, lines, linkage and control levers. Systems available, with approximate installed weights, are:

One valve (internal) for bulldozer 520 lb. (236 kg)
Positions: Raise, hold, lower, float.

Two valve (both internal), for bulldozer and tilt cylinder 660 lb. (299 kg)
Tilt cylinder positions: Tilt right, hold, tilt left.

Two valve (one internal, one external), for bulldozer and ripper 690 lb. (313 kg)
Ripper positions: Raise, hold, lower.

Three valve (two internal, one external), for bulldozer, tilt cylinder and ripper 840 lb. (381 kg)

Pump, gear-type:

	Power Shift	Direct Drive
Capacity @ 1000 psi (69 bar) ...	43 gpm (163 litres/min)	43 gpm (163 litres/min)
RPM @ rated engine speed	1750	1750
Relief valve setting	2250 psi (155 bar)	
Drive	Geared from auxiliary drive	

Reservoir:

Mounting Rear of engine
Tank capacity 13 gallons (49.2 litres)



ROPS

(ROPS canopy is standard in U.S.A. only.)
ROPS (Rollover Protective Structures) offered by Caterpillar for this machine meet ROPS criteria: SAE J395, SAE J1040a and ISO 3471. They also meet FOPS (Falling Object Protective Structure) criteria SAE J231 and ISO 3449.

standard equipment

24-volt direct electric starting.
19-amp alternator.
Blower fan.
Backup alarm (U.S.A. only).
Forward warning horn (U.S.A. only).

Electric hour meter.
Fuel priming pump.
Muffler.
6-roller track frame.
60" (1520 mm) or 74" (1880 mm) gauge.
Sealed and Lubricated Track.

Retrieval hitch.
16" (406 mm) grouser tracks (39-section).
Large idlers.
Hydraulic track adjusters.
Rain cap.
Seat belt.

ROPS canopy (U.S.A. only).
Power shift or direct drive transmission.

optional equipment

(with approximate change in standard operating weight)

Air conditioning systems (for cab only)

Heats only	25 lb. (11 kg)
Cools only	125 lb. (57 kg)
Heats and cools	150 lb. (68 kg)
Alternator, 50-amp (std. with cab)	10 lb. (5 kg)
Backup alarm (std. in U.S.A.)	15 lb. (7 kg)
Cab, ROPS, sound suppressed	2,170 lb. (984 kg)
Canopy, ROPS (std. in U.S.A.)	1,500 lb. (680 kg)
Decelerator	13 lb. (6 kg)
Drawbar, rigid	165 lb. (75 kg)
Swinging	381 lb. (173 kg)
Engine enclosure	180 lb. (82 kg)
Fan, reversible blade	19 lb. (9 kg)
Suction	-14 lb. (-6 kg)
Fire extinguisher	30 lb. (14 kg)
Guards:	
Crankcase, extreme service	600 lb. (272 kg)
For use with ripper or swinging drawbar	585 lb. (265 kg)
Crankcase, normal service	350 lb. (159 kg)
For use with ripper or swinging drawbar	340 lb. (154 kg)
Engine, upper	120 lb. (54 kg)
Final drive	56 lb. (25 kg)
Precleaner	8 lb. (3.6 kg)
Radiator, hinged, heavy-duty	53 lb. (24 kg)
Normal service	10 lb. (5 kg)
Track guiding, center section only	95 lb. (43 kg)
Ends only, 60" (1520 mm) model	160 lb. (73 kg)
74" (1880 mm) model	200 lb. (91 kg)
Track roller, for severe applications and rock conditions	422 lb. (191 kg)
Normal application	150 lb. (68 kg)
For use with end track-guiding guards	320 lb. (145 kg)

Heater, engine coolant	3 lb. (1 kg)
Hook, front pull	50 lb. (23 kg)
Horn	5 lb. (2.2 kg)
Lighting systems:	
Four lights	40 lb. (18 kg)
Two lights	20 lb. (9 kg)
Precleaner with prescreener	6 lb. (3 kg)
Radiator core protector grid	36 lb. (16 kg)
Screen for ROPS cab	80 lb. (36 kg)
Screen for ROPS canopy	60 lb. (27 kg)
Seat, shock dampening	57 lb. (27 kg)
Spring, equalizer, solid, 74" (1880 mm) gauge	90 lb. (41 kg)
Starting motor, low temperature:	
Direct drive model	10 lb. (5 kg)
Power shift model	20 lb. (9 kg)
Sweep, logging, for ROPS cab or canopy	250 lb. (113 kg)
Tool kit	15 lb. (7 kg)
Tracks, pair for 74" (1880 mm) or 60" (1520 mm) gauge:	
Sealed and Lubricated or Sealed (non-lubricated) 39-section:	
18" (457 mm)	218 lb. (99 kg)
20" (510 mm)	390 lb. (177 kg)
22" (560 mm)	550 lb. (249 kg)
Transmission, optional (for direct drive only)	0 lb. (0 kg)
Vandalism protection:	
Instrument panel guard	4 lb. (2 kg)
Cap locks for:	
Oil filler	2 lb. (1 kg)
Oil dipstick	4 lb. (2 kg)
Fuel tank	1 lb. (0.5 kg)
Hydraulic tank	1 lb. (0.5 kg)
Radiator	2 lb. (1 kg)
Water separator	5 lb. (2.2 kg)

Materials and specifications are subject to change without notice.

Longer track life,
lower repair costs.

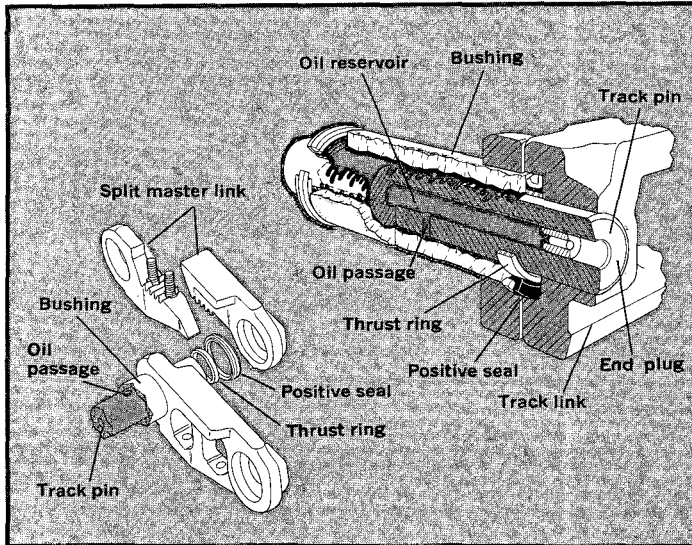

Sealed and Lubricated Track greatly reduces undercarriage maintenance and expense. A special sealing arrangement holds oil between pin and bushing contact surfaces, virtually eliminating internal wear. The pin contains an oil reservoir in the center for continuous lubrication. Sealed and Lubricated Track extends component life throughout the undercarriage assembly and noticeably reduces track noise.

Built-in convenience, comfort and safety
mean more operator efficiency.

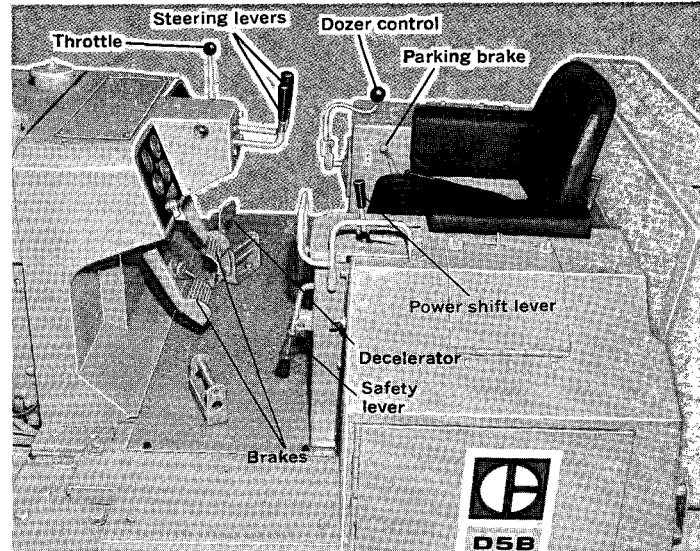

Combined steering and braking means the operator can both disengage steering clutches and apply the brakes with the hand levers. A slight pull on the lever gives a gradual turn . . . all the way back, a pivot turn. Brake pedals are retained for times when operator may prefer them and when the engine is not running.

Single lever dozer control. A single lever at the operator's right hand controls raise, lower and tilt functions. The lever is adjustable for operator comfort and efficiency.

Reliable Cat power train —
efficient, responsive.

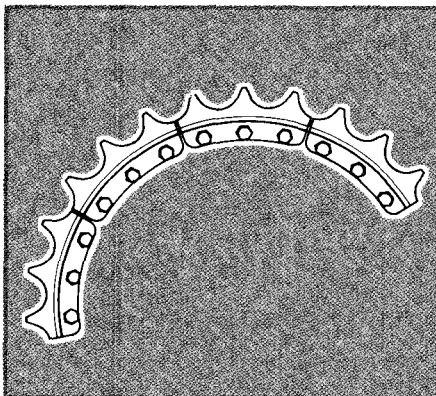

Bolt-on sprocket rim segments save on repair costs and reduce downtime. Sprocket segments can be changed in the field without breaking the track or removing the roller frame. Sprocket profile has been designed to help reduce bushing gouging and pocket wear caused by dirt packing between bushing and sprocket.

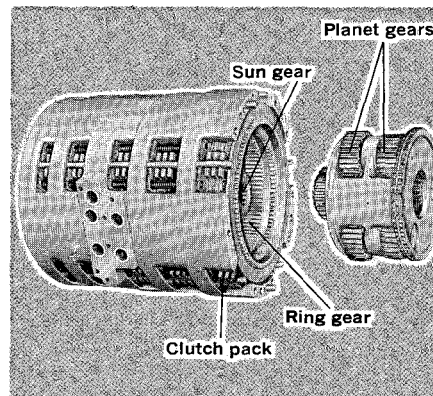

Planetary power shift transmission shifts on-the-go for quick speed and direction changes, fast cycles. Torque loads are spread through planetary gear sets rather than concentrating them on a single, rotating countershaft. Big clutch packs surround each gear set and engage with special hydraulic modulation for smooth, cushioned shifting. Clutch plates and gears are continuously cooled by oil for dependable performance and long life.

Direct drive transmission is also available. Sliding gears are pressure lubricated with filtered oil for long life.

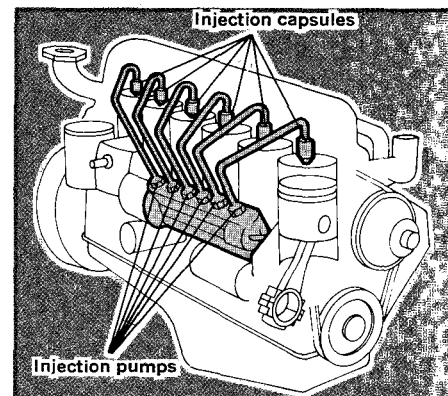

Cat 3306 diesel Engine, with 638 cu. in. (10.5 litres) displacement, delivers reliable power for dozing, ripping, skidding or drawbar productivity. The adjustment-free fuel system has individual fuel injection pumps and valves to meter fuel precisely for efficient performance. Cam-ground and tapered aluminum alloy pistons expand during the heat of combustion to fit snugly in the cylinders for smooth, even power flow.

Serviceability — less time on maintenance, easier repair.

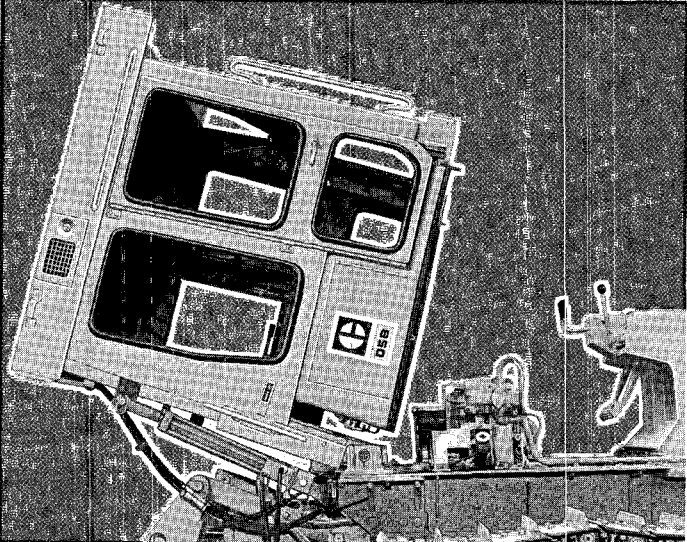

Easy serviceability is designed into the D5B: For day-to-day servicing — a single-piece, removable floor plate provides easy access to transmission top, filters and screens. Hinged doors provide access to batteries in the operator's compartment and fuel shut-off valve at rear of tractor.

The optional sound-suppressed ROPS cab tilts rearward and out of the way if access to power train components is required. (Fuel tank must be removed before cab can be tilted.)



The cab contains many standard operator comfort features: air pressurizer and filter, windshield washers and wipers, tinted glass, dome light and floor mat. Air conditioner and heater are available as options. A cab accessory group is also available including coat hook, sun visor and ash tray.

ROPS canopy is standard in U.S.A. Both cab and canopy meet current OSHA and ISO requirements for operator rollover protection.

Increased machine versatility with rugged Cat-built attachments.

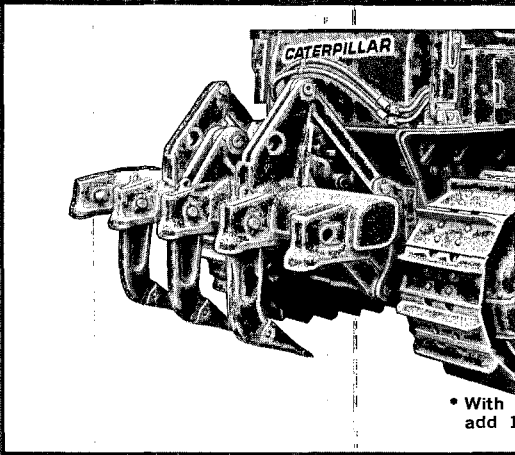

Ripper specifications

- Beam width 7'8" (2340 mm)
- Beam cross-section 8.5" x 10" (216 x 254 mm)
- Maximum penetration .. 18.8" (478 mm)
- Maximum clearance raised (under tip) .. 12.3" (312 mm)
- Shank positions One
- Weight* (without hydraulic controls) .. 3,050 lb. (1380 kg)

* With three teeth; for each additional tooth, add 160 lb. (73 kg).

Parallelogram design No. 5 Ripper maintains a constant tip angle for easy penetration and continuous high production ripping. Complete ripper consists of mounting bracket, linkage as-

sembly, hydraulic cylinder, beam assembly and three teeth with replaceable tips. (Two additional teeth are optional.) Hydraulic control required but not included.

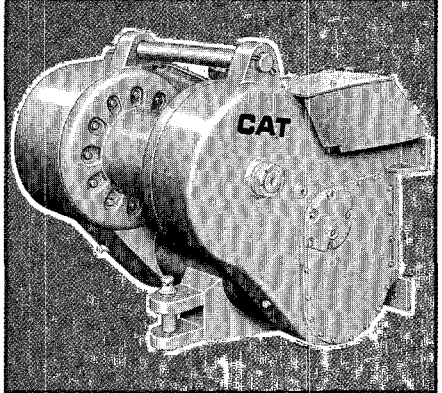

Optional Cat Winch operates with only one lever for easy control of reel-in, reel-out, inching and braking. Drum speeds are matched to tractor ground speeds in first gear, so cable winds and unwinds smoothly. There's easy access for servicing the brakes or gear train.



service refill capacities

	U.S. Gallons	(litres)
Fuel tank	65	(246)
Cooling system	9	(34.1)
Lubricating systems		
Diesel engine crankcase	7.25	(27.4)
Tractor hydraulic system	20.5	(76)
Final drives (each):		
60" (1520 mm) gauge	2.38	(9.0)
74" (1880 mm) gauge	3	(11.4)



weight (approximate)

Shipping (includes lubricants, coolant, ROPS canopy and 10% fuel):

Power shift:

60" (1520 mm) gauge	20,900 lb. (9480 kg)
74" (1880 mm) gauge	21,200 lb. (9620 kg)

Direct drive:

60" (1520 mm) gauge	20,400 lb. (9250 kg)
74" (1880 mm) gauge	20,900 lb. (9480 kg)

Operating (includes lubricants, coolant, full fuel tank, hydraulic control, 5S Bulldozer, ROPS canopy and operator):

Power shift:

60" (1520 mm) gauge	24,800 lb. (11 250 kg)
74" (1880 mm) gauge	25,800 lb. (11 700 kg)

Direct drive:

60" (1520 mm) gauge	25,500 lb. (11 570 kg)
74" (1880 mm) gauge	25,200 lb. (11 400 kg)

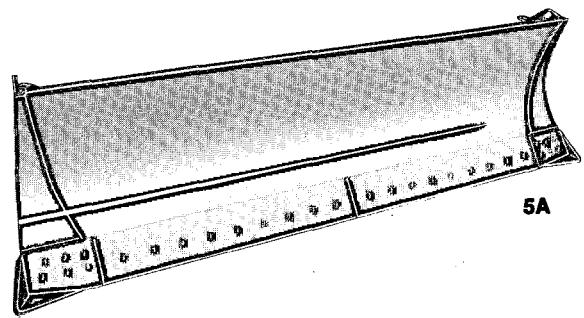

5A

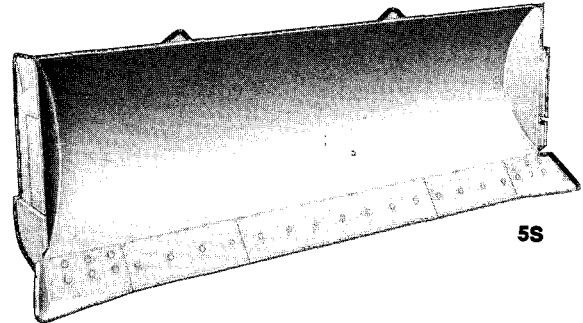

5S

D5B Bulldozers feature a single lever that controls raise, lower and tilt functions. Blades are multiple box-section construction, heat-treated steel moldboards and DH-2 steel cutting edges and end bits. Complete bulldozer consists of dozer moldboard, C-frame for 5A, push arms for 5S, braces, trunnions, lift cylinders and brackets. Hydraulic controls are required but not included with bulldozers.

Bulldozer specifications

Blade	Overall Width (tractor with bulldozer)	Height	Digging Depth	Ground Clearance	Maximum Tilt	Weight (without hydraulic controls)
5S, 60" (1520 mm) gauge	8'8" (2640 mm)	38" (965 mm)	19.9" (505 mm)	34.2" (870 mm)	40" (1015 mm)	3,000 lb. (1360 kg)
74" (1880 mm) gauge	10'4" (3150 mm)	38" (965 mm)	19.9" (505 mm)	34.2" (870 mm)	39.5" (1005 mm)	3,200 lb. (1450 kg)
5A, 74" (1880 mm) gauge						
Straight	11'11" (3630 mm)	33.7" (855 mm)	21.7" (550 mm)	32.2" (820 mm)	11.0" (280 mm)	4,200 lb. (1910 kg)
Angled	10'10" (3300 mm)	33.7" (855 mm)	21.7" (550 mm)	38.2" (970 mm)	11.0" (280 mm)	---



dimensions (approximate)

Ground clearance, from ground face of shoe (per SAE J894) 10.9" (277 mm)

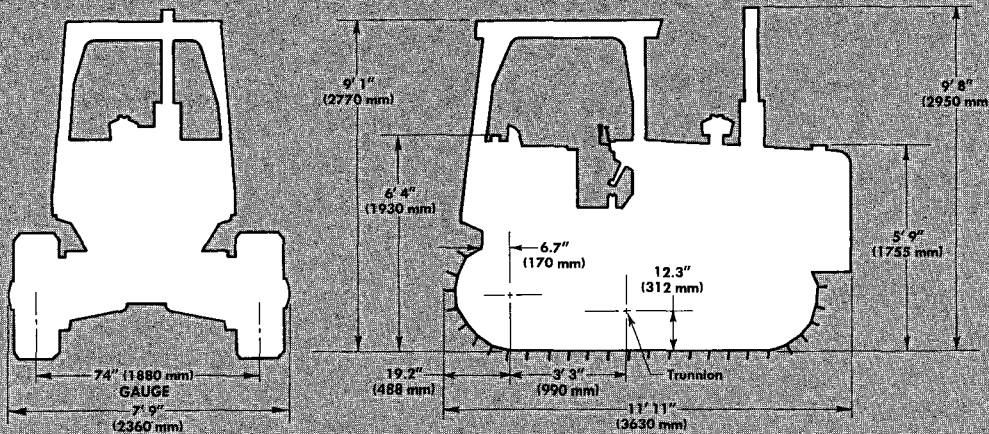

WITH FOLLOWING ATTACHMENTS, ADD TO BASIC TRACTOR LENGTH OF 11' 11" (3630 mm):

RIPPER	3' 7" (1092 mm)
S-DOZER	3' 2" (965 mm)
A-DOZER	3' 1" (940 mm)
A-DOZER ANGLED	5' 6" (1676 mm)

MACHINE HEIGHT FROM TIP OF GROUSER WITH THE FOLLOWING EQUIPMENT:

ROPS CANOPY	9' 3" (2819 mm)
ROPS CAB	9' 10" (2997 mm)
ROPS CAB WITH AIR CONDITIONER	9' 11" (3023 mm)



GEO. P. BANE, INC. / 3402 N NE LOOP 323 / TYLER, TEXAS 75708 / 214/597-6641 / MAILING ADDRESS:
GEORGE P. BANE, INC.
P.O. BOX 4665
TYLER, TEXAS 75712-4665

VOL 008 PAGE 949

January 23, 1984

Honorable Judge and
County Commissioners
Tyler County
Woodville, Texas 75979

Gentlemen,

We are pleased to submit the following quote on your equipment needs.

One new Fiatallis 10C Crawler Tractor equipped as follows:

- Audible Alarm;
- Air Cleaner - Dry Type;
- 45 AMP Alternator;
- Brush Sweeps;
- Back-Up Alarm;
- Batteries - Two 12 Volt, 180 AMP Hours;
- Brakes - Oil Cooled Contracting Band;
- Drawbar - Fixed;
- Engine - 122 H.P., 494.4 cu. in.;
- Engine Side Panels - Lower;
- Final Drives - Double Reduction;
- Front Pull Hook;
- Hydraulics - Closed System w/Internal
Magnetic Filters & Suction Screen;
- Moldboard - Angle w/Hydraulic Tilt;
- Cold Weather Starting Aid;
- Radiator Sand Screen;
- ROPS Canopy;
- Spark Arrestor;

CONSTRUCTION EQUIPMENT

SALES - SERVICE - PARTS - RENTALS

Torque Converter - Single Stage Rotating
Housing;
Hydraulic Track Adjusters;
Track Shoes - 19.75" Full Grouser;
Transmission - Powershift, 3F x 3R;
Vandalism Protection - Provisions for Locking
Battery Box, Fuel Tank Cap, Hydraulic Tank
Cap, Instrument Panel, Radiator Cap;
Extended 2 Yrs/5000 Hrs. Powertrain Warranty.

List Price\$85,495.00
Less Trade-in (John Deere S/N 25919) 26,258.00
Bid Price\$59,237.00

We appreciate the opportunity to bid on your equipment needs
and hope to be of help in this instance.

Sincerely yours,

GEORGE P. BANE, INC.

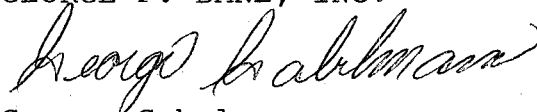

George Gabelmann
Sales Manager

GG/ma

ACCEPTED:

10-C

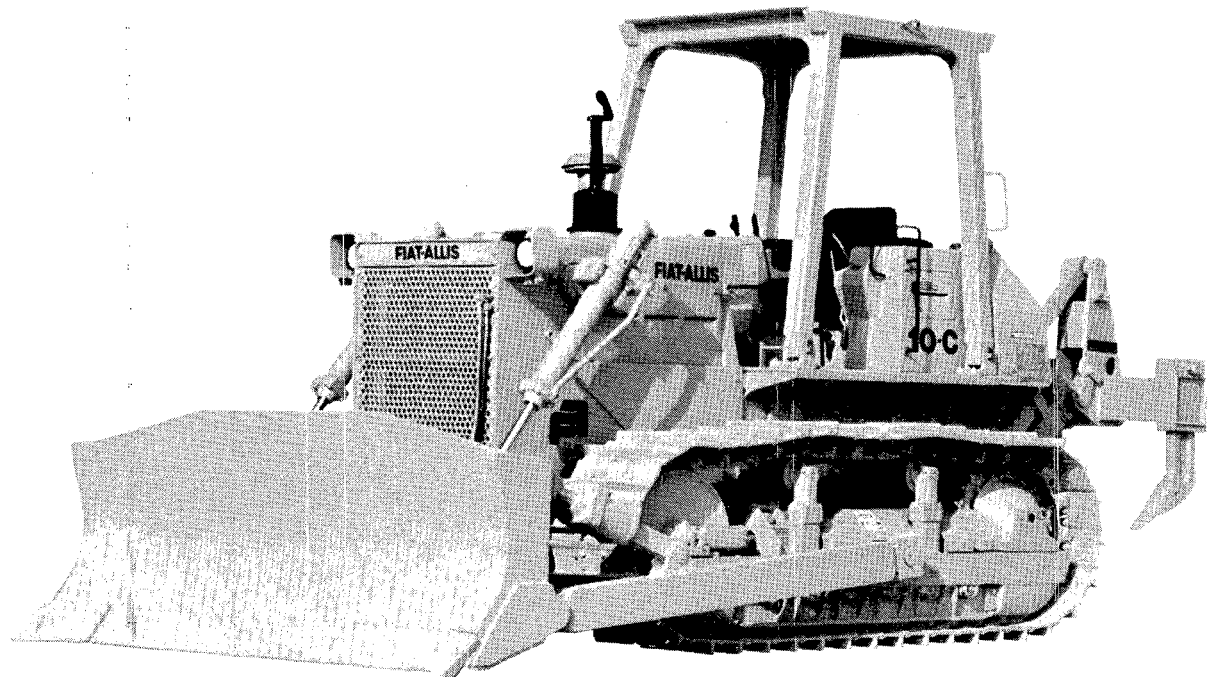

10-C Crawler Tractor

Unit is shown with optional equipment

TORQUE CONVERTER W/POWER SHIFT . . . 122 FLYWHEEL H.P. OIL MASTER CLUTCH W/POWER SHIFT . . .

OPERATING WEIGHT WITH ROPS CANOPY

- With semi-U dozer 27,976 lbs. (12690 kg)
- With angledozer 28,263 lbs. (12820 kg)

POWER

- 6 cylinder naturally aspirated direct injection Fiat engine . . . low fuel consumption . . . 122 net flywheel horsepower

TRANSMISSION — CHOICE OF CONFIGURATIONS:

- High efficiency torque converter with full power shift. Three forward and three reverse speeds.
- Automatic oil master clutch with full power shift. Four forward and four reverse speeds by high-low selector.

PROFITABILITY

- Power . . . Weight . . . Operator comfort and convenience . . . Easy maintenance . . . Fuel economy, and Reliability.

VERSATILITY

- Semi-U blade with EQUISTATIC[®] load compensator and one hydraulic tilt cylinder.
- Angle blade with two hydraulic tilt cylinders.
- Angle blade with manual tilt.
- Parallelogram ripper.

PRODUCTIVITY

- Open shift single lever pattern on power-shift transmission with converter
- Clutch engagement controlled automatically by single lever on power shift transmission with master clutch.

10-C SPECIFICATIONS



ENGINE

Flywheel horsepower (SAE)*	122
Kilowatts**	91
Din horsepower***	127
Make and model	Fiat 8365
Type	Diesel 4-cycle, naturally aspirated, direct injection
Governed RPM	2100
Number of cylinders	6
Bore and stroke	4.53 x 5.12" (115 x 130 mm)
Displacement	494 cu. in. (8.1 lit)
Lubrication	Full pressure
Fuel	No. 2 diesel

*The net flywheel horsepower of the vehicle engine under SAE standard conditions of 85°F (29°C) and 29.98" (736 mm) Hg. after deductions have been made for fan, alternator, lube oil pump, air cleaner, fuel pump, and muffler.

**Kilowatts is the International System of Units for power. One (1) horsepower (SAE) equals 0.746 kilowatt.

***The net flywheel horsepower of the vehicle engine under Din standard conditions of 68°F (20°C) and 28.98" (736 mm) Hg. after deductions have been made for fan, alternator, lube oil pump, water pump, air cleaner, fuel pump, and muffler.



ELECTRICAL SYSTEM

Voltage	24V
Standard Alternator	30 amp
Battery amp/hour rating (each)	95



TORQUE CONVERTER AND FULL POWER-SHIFT

TORQUE CONVERTER

Type	Single stage, rotating housing
Torque multiplication ratio	2.3:1



TRANSMISSION

Type	Powershift, constant mesh countershaft
Control	Single lever
Clutches	Multi-disc, hydraulically actuated
Lubrication	Full pressure
Modulating valves	2

Gear	Forward Speed		Reverse Speed	
	MPH	Km/h	MHP	Km/h
1st	0-2.4	(0-3.8)	0-2.9	(0-4.7)
2nd	0-3.9	(0-6.3)	0-4.8	(0-7.8)
3rd	0-6.2	(0-10.0)	0-7.5	(0-12.0)

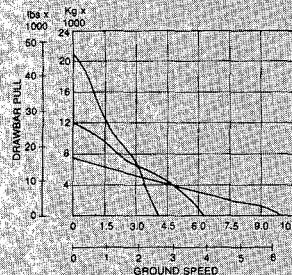

*Drawbar tractive efforts depend on coefficient of traction, rolling resistance and crawler dozer operating weight.



AUTOMATIC MASTER CLUTCH AND POWER-SHIFT

Type	Oil bath, dual disc with sintered metal linings
Operation	Hydraulic, synchronized with transmission
Control	Automatic by power shift control lever



TRANSMISSION

Type Countershaft, constant mesh with hydraulic power-shift selection of 2 forward speeds and 2 reverse speeds. High-low ranges selected mechanically.

Control Single lever simultaneously controls transmission speed selection and automatic clutch. Separate lever mounted beside power-shift lever mechanically selects high/low ranges to give a total 4 speeds forward and 4 reverse speeds. A Special valve permits gradual engagement of the main clutch to give inching control.

Modulating valves 2

Gear	Forward Speed		Reverse Speed	
	MPH	Km/h	MHP	Km/h
1st Lo	1.5	(2.4)	1.6	(2.6)
2nd Lo	2.2	(3.6)	2.4	(3.9)
1st Hi	3.4	(5.5)	3.7	(5.9)
2nd Hi	5.1	(8.2)	5.5	(8.8)

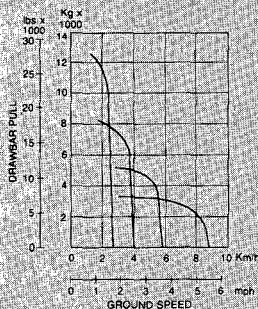

*Drawbar tractive efforts depend on coefficient of traction, rolling resistance and crawler dozer operating weight.



STEERING AND BRAKING SYSTEMS

STEERING CLUTCHES

Type	Hydraulically actuated, multiple disc, oil bath, requires no adjustment, independent servicing
Number of Driven Plates (each side)	12
Total Friction Area — Each Clutch	1063 sq. in. (6859 cm ²)
Control	Dash mounted levers

BRAKES

Type	Oil cooled, contracting band acting on steering clutch outer drum, mechanically actuated with hydraulic assist.
Total Friction Area — Each Brake	145 sq. in. (937 cm ²)
Control	Two separate pedals
Parking Brake	Mechanical



FINAL DRIVES

Type	Double reduction
Ratio	11.2:1
Lubrication	Oil bath



TRACK

Hydraulic track adjusters. Sprockets have two piece bolt on replaceable segments. Inner and outer sprocket guards. Disc idlers. Outside mounted carrier rollers. Front and rear Track guiding guards. Lifetime lubricated track rollers, carrier rollers and idlers with metal to metal seals.

Track Frame	Oscillating
Track Rollers (each side)	6
Double Flange	3
Single Flange	3
Carrier Rollers (each side)	2
Number of Shoes (each side)	40
Width of Standard Shoe	19 1/4" (500 mm)
Length of Track on Ground	90" (2285 mm)
Ground Contact Area — standard shoes	3,555 sq. in. (2,29 m ²)
Gauge	67 3/4" (1720 mm)
Ground Clearance (per SAE J894)	14 1/2" (370 mm)
Track Oscillation	9 1/2" (243 mm)



HYDRAULIC SYSTEM

Reservoir	Closed
Mounting	Rear of tractor
Pump	Gear
Capacity @ 2100 engine RPM	39.6 U.S. gal/min (150 lit/min)
Relief valve pressure	2210 psi (153 bar)
Control Valve	Externally mounted, standard three spool
Control — blade/tilt	Single lever
Blade Positions	Raise, hold, lower, float
Tilt Positions	Left, hold, right
Auxiliary Circuit	For optional equipment
Cylinders	Double action
Dozer, with quick drop and limit travel valves	Two
Bore x Stroke	3.94 x 33.07" (100 x 840 mm)
Tilt, Semi-U	One, left side
Bore x Stroke	7.09 x 5.51" (180 x 140 mm)



FILTRATION SYSTEMS

ENGINE	
*Lubricating oil	Two spin-on, 10 micron
Fuel	One spin-on, 10 micron
	One spin-on, 30 micron
*Air Cleaner	Dry type with inner safety element

TRANSMISSION (TORQUE CONVERTER and CLUTCH)	
Intake	Full flow 100 micron metallic element
*Delivery	Full flow 30 micron

STEERING AND BRAKING

Intake	Full flow 100 micron with magnetic rod
*Return	Full flow 15 micron

HYDRAULICS

Intake	Full flow 250 micron with magnetic rod
*Return	20 micron

*Restriction indicator on instrument panel in operators compartment.



CAPACITIES

ENGINE	U.S. Gal.	Litres
Lubricating Oil	4 3/4	18
Coolant	8 3/4	33
Fuel Tank	68 3/4	260
TRANSMISSION		
Converter and Transmission	10 3/4	41
Clutch and Transmission	8	30
Steering and Braking System	8	30
Final Drives (each)	4	15.5
HYDRAULIC SYSTEM		
Semi-U Dozer	13 3/4	52
Angle Dozer with Hyd. Tilt	15 1/2	58.5
With Ripper (add)	2 1/4	8.5

DIMENSIONS — In (mm)

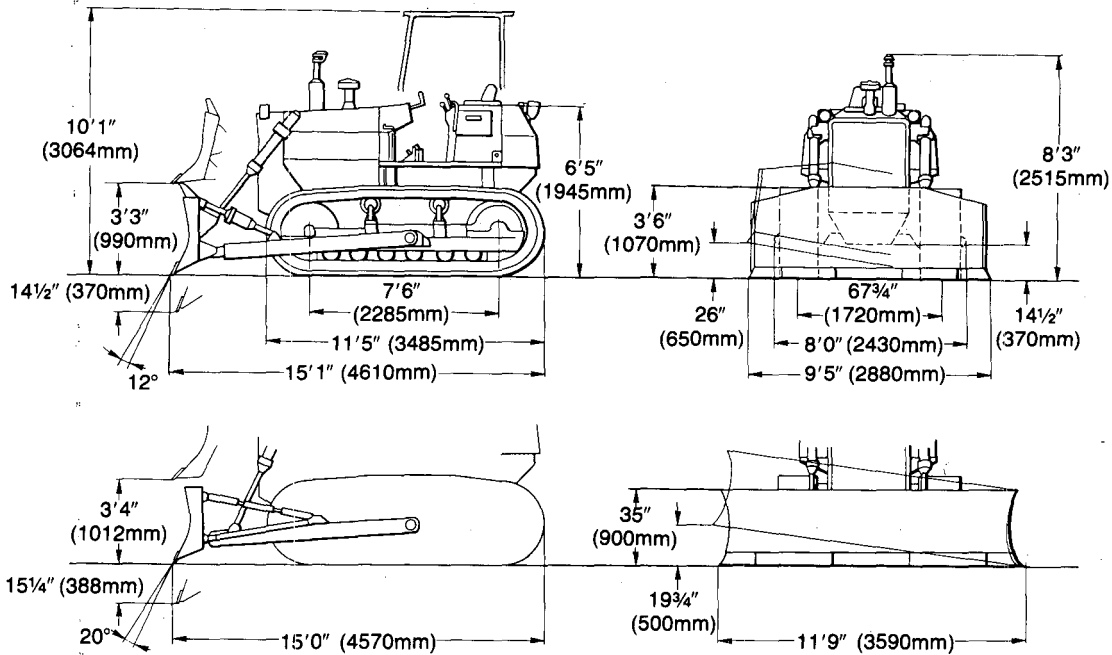

WEIGHT

Operating Weight (includes lubricants, coolant, full fuel tank, hydraulics, ROPS canopy and operator):

- Semi-U with tilt 27,976 lbs. (12690 kg)
 - Angle with tilt 28,263 lbs. (12820 kg)
- Shipping Weight (includes dozer lift cylinders, hydraulics, and 10% fuel capacity) 24,052 lbs. (10910 kg)



ROPS

Rollover Protective Structures (ROPS) offered by Fiat-Allis for this machine meet ROPS criteria: SAE J1040a, SAE J320, SAE J394, SAE J395, SAE J396, SAE J1011, and ISO 3471. They also meet Falling Object Protective Structure (FOPS) criteria SAE J231 and ISO 3449. ROPS canopy is standard in U.S.A. and Canada.



DOZER

- Width, blade straight, overall
- Width, blade angled, overall
- Height
- Length, blade straight, overall
- Length, blade angled, overall
- Blade angle, either side
- Width of "C" frame
- Width over trunnions
- Weight (includes moldboard, "C" frame or push beams, struts, trunnions, tilt cylinder)

Semi-U

- 9'5" (2880 mm)
-
- 42" (1070 mm)
- 15'1" (4610 mm)
-
-
- 8' (2430 mm)
- 3550 lbs. (1610 kg)

Angle

- 11'9" (3590 mm)
- 10'8" (3254 mm)
- 35" (900 mm)
- 15' (4570 mm)
- 17'4" (5290 mm)
- 25°
- 8'7" (2618 mm)
- 8' (2430 mm)
- 3910 lbs. (1740 kg)



RIPPER

- Type
- Max. ripping depth
- Ripping width
- Overall width
- Number of Shanks (standard)
- Shank depth adjustment holes
- Max. clearance under raised shank
- Clearance — beam fully lowered
- Spacing — center to center of shank
- Shank, cross section
- Shank, weight (w/tooth)
- Tooth weight
- Hydraulic cylinders
- bore and stroke
- Length — Semi-U Dozer and Ripper
- Angle Dozer and Ripper
- Weight (incl. Hydraulics)

R10-C

- Parallelogram
- 17 1/2" (445 mm)
- 5'7" (1700 mm)
- 7'0 3/4" (2150 mm)
- 3
- 2
- 17 1/4" (440 mm)
- 8 3/4" (225 mm)
- 37 3/4" (960 mm)
- 2 3/8" x 9 1/2" (60 x 240 mm)
- 198 lbs. (90 kg)
- 13 1/4 lbs. (6 kg)
- One-double acting
- 5.5" x 24.6" (140 x 625 mm)
- 20'10" (6349 mm)
- 20'8" (6309 mm)
- 4056 lbs. (1840 mm)



STANDARD EQUIPMENT

- Air cleaner with safety element
- Alternator, 30A
- Anti-freeze
- Batteries, two 12V
- Backup alarm
- Control valve, three spools
- Decelerator, foot operated
- Drawbar, fixed
- Electrical outlets, two 24V
- Engine side panels, lower
- Fan, pusher
- Guards:
Crankcase, converter and transmission
Lower sprocket
Front and rear upper track guiding
Inner and outer track frame
- Hydraulics include:
Tank; filters; pump; dozer cylinders, piping and brackets; single lever dozer-tilt control
- Instruments, gauges:
Electric hourmeter; engine oil pressure; fuel level; water temperature; trans oil pressure — clutch apply; trans oil temperature
- Instruments, warning lights: air cleaner filter; alternator; engine oil filters; fuel pressure; hydraulic oil filter; steering and braking oil filter; trans oil filter; trans lube oil pressure
- Muffler with raincap
- Radiator sand screen
- ROPS canopy & seat belt
- Starting, 24V direct electric
- Tool box
- Track adjusters, hydraulic
- Track carriers, 2 each side
- Track rollers; 3 double flange & 3 single flange each side
- Track shoes, 19¾" (500 mm), full grouser
- Transmission, choice of:
Full powershift with converter
Full powershift with automatic master clutch
- Vandalism protection, provision for full locking



OPTIONAL EQUIPMENT

- Air conditioning
- Alternator, 47A
- "C" frame guides (for 21¾"-550 mm shoes)
- Cold weather ether starting aid
- Dozer equipment:
Semi-U w/Hyd. tilt & EQUISTATIC®
Angle w/Hydraulic tilt
Angle w/manual tilt
- Drawbar, heavy duty
- Drawbar, swinging
- Fan, reversible
- Guards:
Cab or canopy sweeps
Tilt cylinder
Full length track roller
- Engine side panels, upper
- Lights, 2 front & rear
- Pull hook, front
- ROPS cab
- Rear screens, for cab or canopy
- Ripper; R10C parallelogram w/3 shanks
- Seat, suspension
- Tool kit
- Track shoes, 21¾" (550 mm)



The information contained herein is general in nature and is not intended for specific application purposes. Fiat-Allis reserves the right to make changes in specifications shown herein or add improvements at any time without notice or obligation. Illustrations show standard and optional items.

GEORGE P. BANE, INC.
P.O. Box 4665
Tyler, Texas 75712-4665



FIATALLIS 5000-HOUR/2-YEAR POWER TRAIN WARRANTY

WARRANTY COVERAGE: This warranty protects your machine investment over and above the Fiatallis Standard 6-Month Warranty. For 5000 HOURS OR TWO (2) FULL YEARS, whichever comes first, Fiatallis warrants the following power train components to be free of defects in workmanship and material at the time of shipment from the factory.

FIAT ENGINE*	BEVEL GEAR	STEERING CLUTCHES
TORQUE CONVERTER	CROSS SHAFT and	FINAL DRIVE or
TRANSMISSION	BEARINGS	AXLE PARTS

The external hardware and parts of the power train components — such as hoses, tubes, valves, pumps and filters, and the steering and braking components on rubber-tired machines — are not covered by this warranty.

This warranty is effective on all Fiat diesel powered construction equipment sold in North America on or after March 1, 1981. Warranty coverage begins on the date the new Fiatallis machine is delivered to you. If you sell the machine during the warranty period, you can transfer the unexpired warranty to the new owner merely by notifying your Fiatallis Dealer.

FIATALLIS RESPONSIBILITIES: We will repair or replace (at our option) any power train components that fail to conform to this warranty, subject to the conditions stated below. We also warrant any part installed in a power train component to correct a warrantable failure for the duration of the unexpired power train warranty.

CUSTOMER RESPONSIBILITIES: As conditions of this warranty, you must make arrangements for the quarterly inspections by your dealer and notify him when and where the inspection can be performed. In the event the machine is moved to another dealer's territory, simply notify that dealer for continued inspections and warranty coverage. Failure to have these quarterly inspections performed will invalidate this warranty.

In the event of a warrantable component failure, you are also required to have the repair or replacement work done by an authorized Fiatallis Dealer.

DEALER RESPONSIBILITIES: At no charge to you, your Fiatallis Dealer will provide any parts, labor, lubricants and filters required to correct a warrantable failure on a power train component. He will report major problems to Fiatallis via Hotline, and will return all replaced parts to Fiatallis, transportation charges prepaid.

He will perform, at no additional cost, a complete preventive maintenance inspection of your machine every three (3) months during the 5000-HOUR OR 2-YEAR WARRANTY period, and will submit to Fiatallis coupons indicating inspection completion.

CONDITIONS: THIS POWER TRAIN WARRANTY AND THE STANDARD 6 MONTH WARRANTY ARE THE EXCLUSIVE FIATALLIS WARRANTIES WITH RESPECT TO THE COMPONENTS LISTED ABOVE, AND ARE IN LIEU OF ALL OTHER WARRANTIES, EXPRESS OR IMPLIED, INCLUDING ANY WARRANTY OF MERCHANTABILITY OR FITNESS FOR A PARTICULAR PURPOSE.

NO WARRANTY OF ANY KIND IS MADE OR SHALL BE IMPOSED ON FIATALLIS WITH RESPECT TO POWER TRAIN COMPONENTS SUBJECTED TO OPERATION IN EXCESS OF RECOMMENDED CAPACITIES, MISUSE, NEGLIGENCE OR ACCIDENT, OR THAT HAVE BEEN ALTERED OR REPAIRED IN ANY MANNER NOT AUTHORIZED BY FIATALLIS.

THE LIABILITY OF FIATALLIS ARISING FROM WARRANTS, REPRESENTATIONS, INSTRUCTIONS OR DEFECTS FROM ANY CAUSE SHALL BE LIMITED EXCLUSIVELY TO THE REPAIR OR REPLACEMENT OF PARTS UNDER THE CONDITIONS DESCRIBED ABOVE. FIATALLIS IS NOT LIABLE FOR DIRECT OR INDIRECT INCIDENTAL OR CONSEQUENTIAL DAMAGES OR LOSS OF USE FOR ANY REASON.

*Machines equipped with a factory-installed Cummins engine are warranted by the standard Cummins Warranty policy for one (1) year. The Warranty is administered by local Cummins distributors.

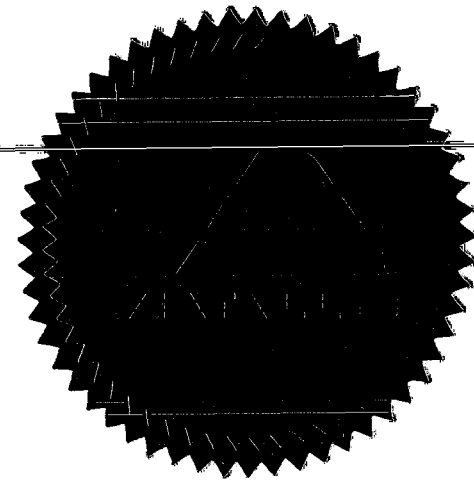

BIRDWELL'S WELDING & MACHINE SHOP

PORTABLE WELDING EQUIPMENT

D. G. BIRDWELL

DAY PHONE 283-3405 — NIGHT PHONE 283-2658

202 EAST BLUFF STREET

WOODVILLE, TEXAS 75979

DATE

1-23 1984

VOL 008 PAGE 952

BID ON TRAILERS
FOR PRECINCT 1 & 4

#14,095.00 per trailer

45 DAYS DELIVERY
EACH TRAILER

TRAILERS BUILT PER
COUNTY SPECIFICATIONS

Birdwell's Welding & Machine Shop
202 East Bluff Street
WOODVILLE, TEXAS 75979

008 PAGE 953
VOL 11

BID ON TRAILERS

NO. _____ TIME: 9:20 AM

JAN 23 1984

GRACE BOSTICK, COUNTY CLERK
CLERK OF COURTS
EVA *Eva Grace Bostick*



GEO. P. BANE, INC. / 3402 N NE LOOP 323 / TYLER, TEXAS 75708 / 214/597-6641 /

MAILING ADDRESS:
GEORGE P. BANE, INC.
P.O. BOX 4665
TYLER, TEXAS 75712-4665

January 23, 1984

Honorable Judge and
Commissioners Court
Tyler County
Woodville, Texas 75979

Gentlemen:

We are pleased to submit a bid on your equipment needs.

One new Supreme Trailer equipped as follows:

- 15 Ton Flatbed;
- 2" Oak Deck;
- 8' Wide x 16" Long w/4' Dovetail;
- Electric Brakes;
- 8.25 x 15 Tires;
- 3" Adjustable Eye Hitch;
- 6 Heavy Duty Lashing Rings;
- 5000 lb. Capacity Jack;
- Tandem Suspension;
- Oil Bath Bearings w/Transparent Hubs;
- Flip Ramps;
- Military Pintle Hook.

Bid Price\$10,459.00

We appreciate the opportunity to bid on your equipment needs and hope to be of help in this instance.

Sincerely,

GEORGE P. BANE, INC.

George Gabelmann
George Gabelmann
Sales Manager

One trailer for Precinct #1- \$10,459.00
One trailer for Precinct #4- \$10,459.00

Joe Lee Powell

GG/ma

Tyler County
Woodville, TX

January 23, 1984

VOL 008 PAGE 955

ACCEPTED:

January 23, 1984

Honorable Judge and
Commissioners Court
Tyler County
Woodville, Texas 75979

Gentlemen:

We are pleased to submit a bid on your equipment needs.

One new Supreme Trailer equipped as follows:

- 15 Ton Flatbed;
- 2" Oak Deck;
- 8' Wide x 16" Long w/4' Dovetail;
- Electric Brakes;
- 8.25 x 15 Tires;
- 3" Adjustable Eye Hitch;
- 6 Heavy Duty Lashing Rings;
- 5000 lb. Capacity Jack;
- Tandem Suspension;
- Oil Bath Bearings w/Transparent Hubs;
- Flip Ramps;
- Military Pintle Hook.

Bid Price\$10,459.00

We appreciate the opportunity to bid on your equipment needs and hope to be of help in this instance.

Sincerely,
GEORGE P. BANE, INC.

George Gabelmann
Sales Manager

GG/ma

COPY

Tyler County
Woodville, TX

January 23, 1984

VOL 008 PAGE 957

ACCEPTED:

C
O
P
Y

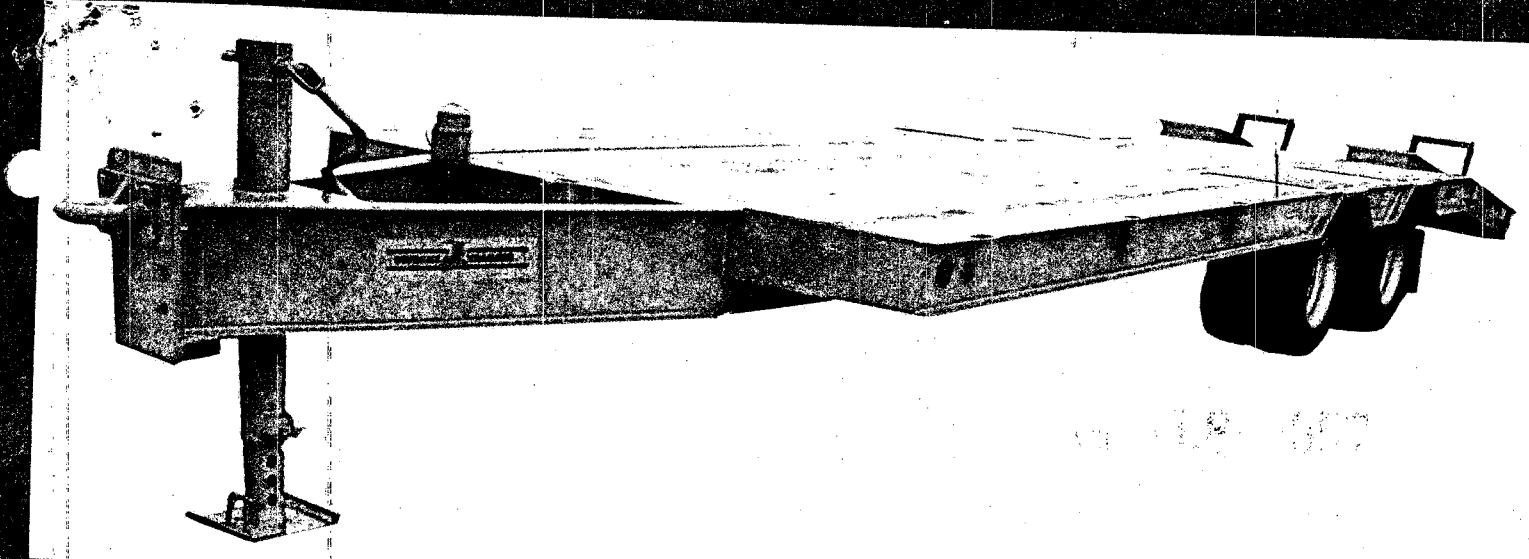

PULL-TYPE DOVETAILS

P20+5

P25+5

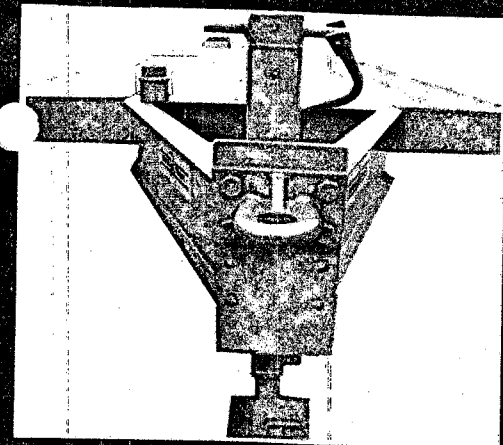

Jack — heavy-duty single speed drop-foot for ease and safety in coupling and uncoupling.

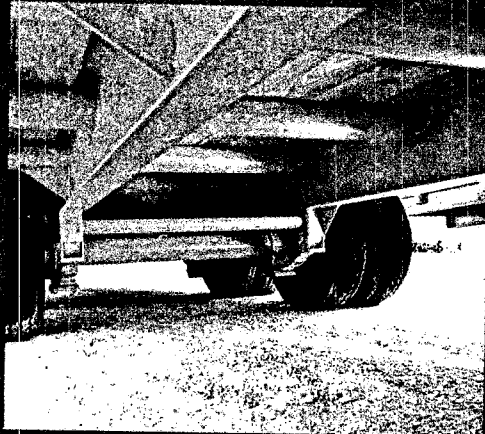

Mainframe — four I-beam construction with tubular crossmembers run through mainframe for lower deck height, greater strength and maximum deck rigidity against twisting.

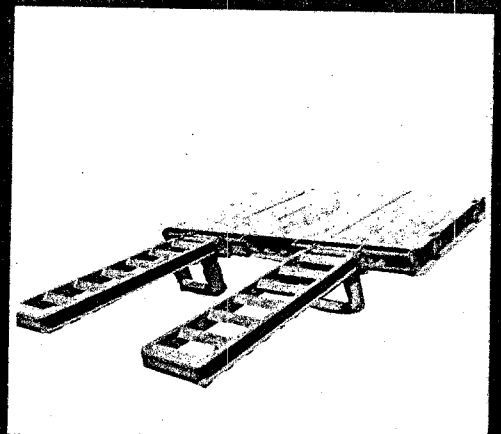

Flip-over ramps — two 5 feet long ramps for ease and safety in loading.

SUPREME



TRAILERS INC.

(817) 799-4941

P.O. Box 4308 Waco, Texas 76705

General Specifications

PULL-TYPE DOVETAILS

P20 + 5

P25 + 5

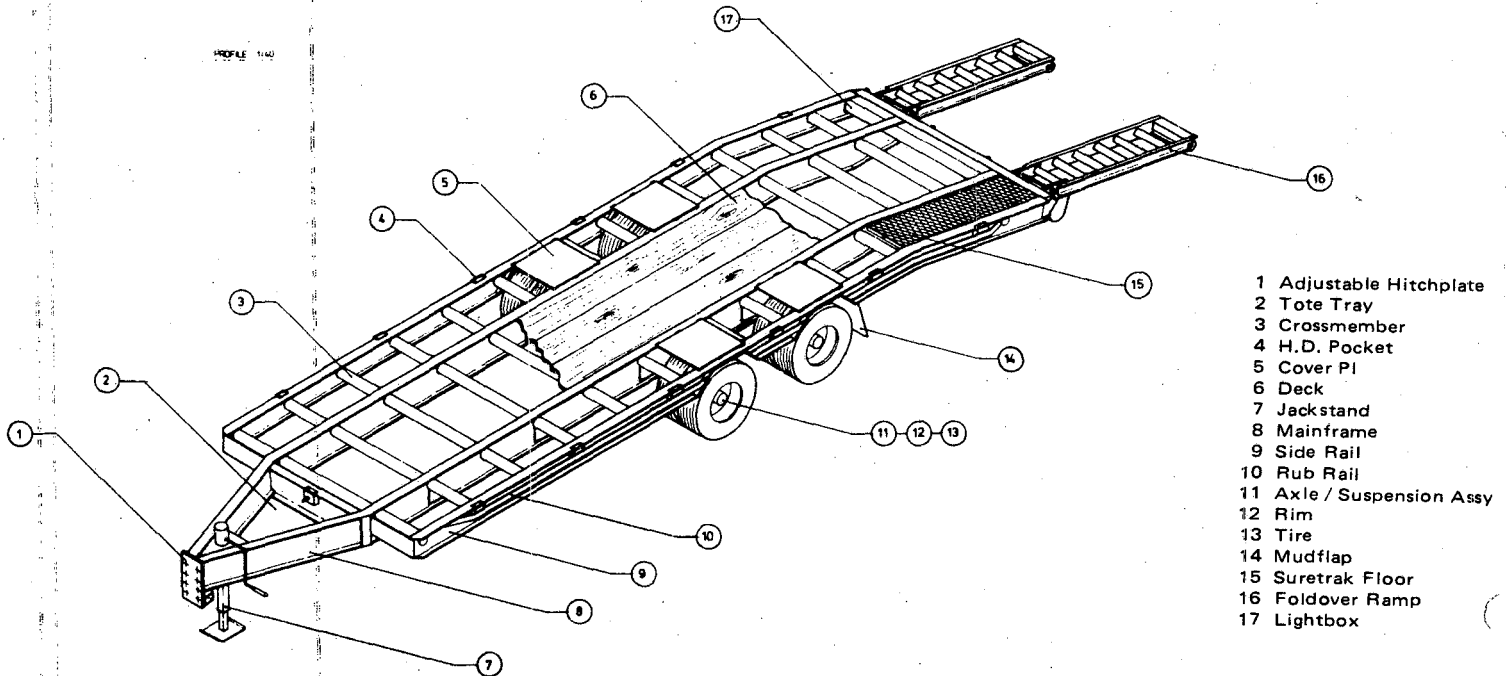
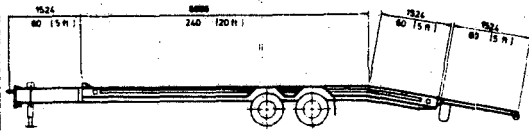

- 1 Adjustable Hitchplate
- 2 Tote Tray
- 3 Crossmember
- 4 H.D. Pocket
- 5 Cover Pl
- 6 Deck
- 7 Jackstand
- 8 Mainframe
- 9 Side Rail
- 10 Rub Rail
- 11 Axle / Suspension Assy
- 12 Rim
- 13 Tire
- 14 Mudflap
- 15 Suretrak Floor
- 16 Foldover Ramp
- 17 Lightbox

STANDARD LENGTHS — deck lengths of 20 or 25 feet plus dovetail length of 5 feet and flip-over ramp length of an additional 5 feet.

AXLES — two 10,000 pound capacity high quality, oil lubricated with 70 inch track and 48-1/4 inch axle centers.

SUSPENSION — tandem with 5-leaf springs, lubrication-free rubber mounted anti-hop type for increased stopping efficiency and better tire wear.

WHEELS — 16.5 inches by 6.75 inches one-piece disc type 8 hole duals with 6-1/2 inch bolt pattern.

TIRES — 8.75 by 16.5 truck-type tubeless with 10-ply rating.

BRAKES — vacuum actuated hydraulic disc type standard (electric brakes optional).

LANDING GEAR — single drop-leg with crank on driver's side.

PAINT - Swift red standard (other colors optional), with wheels of aluminum color.

DECK HEIGHT — 32 inches.

G.V.W.R. — 21,000 pounds.

MAINFRAME — 12 inch, wide flanged I-beam, 16 pounds per foot, punched for tubular crossmembers on approximate 24 inch centers for greater strength and maximum deck rigidity.

CROSSMEMBERS — 4-1/2 inch O.D. round tubing with 1/8 inch wall thickness.

SIDERAILS — 8 inch, wide flanged I-beam, 10 pounds per foot.

FLOOR — 2 inch treated yellow pine standard with boards running lengthwise with mainframe.

HITCH — pintle ring standard (2-5/16 inch ball coupler with positive lock pin optional) with height adjustable from 24 inches to 30 inches.

LIGHTS — recessed, sealed beam rubber shock mounted with soldered electrical connections, ICC standards.

ELECTRICAL RECEPTACLE — 6 way 12 volt

STAKE POCKETS — recessed design, standard (tie-rings and rub rails optional).

WARRANTY — 90-day limited warranty.

Design and Specifications subject to change without notice.

Supreme — The Leader Among Trailers



Mustang

TRACTOR & EQUIPMENT CO.

HOUSTON, TEXAS 77040 12800 Northwest Freeway (713) 460-2000

BEAUMONT, TEXAS 77706
7990 Eastex Freeway
(713) 892-8412EL CAMPO, TEXAS 77437
Highway 71 (North)
(713) 543-3389LUFKIN, TEXAS 75901
Highway 69 (S.E.)
(713) 639-5551BRYAN, TEXAS 77801
3605 S. College St.
(713) 846-7761

VOL 008 PAGE 959

QUOTATION

TO

Tyler County Pct. 1 & 4
Woodville, Texas 75979

QUOTATION NO. S84-5

DATE January 6, 1983

CUSTOMER INQUIRY NO.

IMPORTANT: WHEN ORDERING, PLEASE MENTION
ABOVE QUOTATION NUMBER AND DATE.

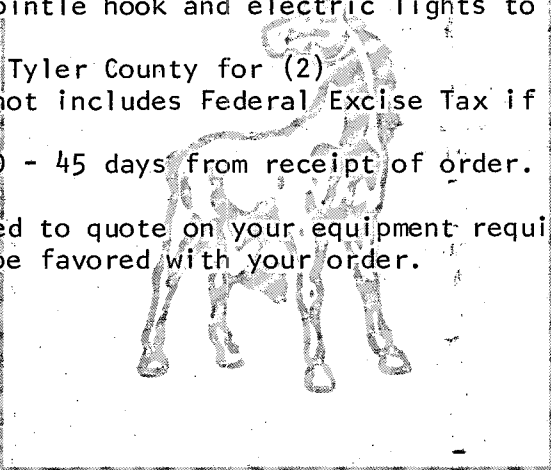
QUAN.	DESCRIPTION	UNIT PRICE	EXTENSION
2	<p>We are pleased to submit the following for your consideration:</p> <p>New Hercules 15 ton draw bar trailers, 2-inch thick oak deck, 8-foot wide and 16-foot long, 4-foot dovetail, Dexter electric brakes, 15"inch cast spoke wheels with Stemco sight glass hubs, dual axle, dual tires (8:25 x 15), 3-inch adjustable eye hitch, 6 heavy duty lashing rings, 5,000 pound capacity jack for empty trailer, flip ramps, and includes mounting of pintle hook and electric lights to county vehicle.</p> <p>Price F.O.B. Tyler County for (2) (Price does not includes Federal Excise Tax if applicable.)</p> <p>Delivery: 30 - 45 days from receipt of order.</p> <p>We are pleased to quote on your equipment requirements and hope we may be favored with your order.</p> 		\$20,485.00
APPLICABLE WARRANTY(S): Hercules PRICES ARE F.O.B.: Tyler County, Texas			

THIS QUOTATION SHALL TERMINATE UNLESS MUSTANG RECEIVES WRITTEN ACCEPTANCE WITHIN 30 DAYS HEREOF.

ACCEPTED THIS DAY OF _____, 19____

By _____
(If signing for a corporation or partnership, include name of customer and title of person signing.)

MUSTANG TRACTOR & EQUIPMENT COMPANY

By Jim Lindsey Area Manager
(TITLE)

THIS QUOTATION IS SUBJECT TO THE TERMS AND CONDITIONS CONTAINED ON THE REVERSE SIDE HEREOF, SAME BEING INCORPORATED HEREIN BY REFERENCE.

1. Price, Terms of Payment. All prices are exclusive of sales and any other applicable taxes. Unless terms acceptable to Mustang Tractor & Equipment Company, ("Mustang") are agreed to in advance, all prices are payable in full prior to delivery. Orders are placed at manufacturer's current list price. In the event of price changes by manufacturer, the price prevailing at time of delivery will be paid by purchaser.

2. Product Warranty, Disclaimer and Limitation. The only warranties, if any, applicable to any item of machinery, equipment or other personal property subject hereto are identified on the reverse side hereof.

2.1. New Products. Mustang will not make any warranties, express or implied, regarding any new item of machinery, equipment or other personal property subject hereto, and Mustang **DISCLAIMS ALL WARRANTIES, EXPRESS OR IMPLIED, INCLUDING, BUT NOT LIMITED TO, ALL IMPLIED WARRANTIES OF MERCHANTABILITY AND OF FITNESS FOR A PARTICULAR PURPOSE** with respect to each such item. Customer's sole and exclusive remedy, if any, for defects in materials or workmanship with respect to any new item of machinery, equipment or other personal property subject hereto shall be against the manufacturer or manufacturers thereof pursuant to the express, written warranty, if any, extended by such manufacturer or manufacturers with respect to such products and described on the reverse side hereof. If any such express, written warranty is applicable, a copy thereof will be furnished upon request.

2.2. Used Products. Mustang will not make any warranties, express or implied, regarding any used item of machinery, equipment or other personal property and Mustang has expressly **DISCLAIMED ALL WARRANTIES, EXPRESS OR IMPLIED, INCLUDING, BUT NOT LIMITED TO, ALL IMPLIED WARRANTIES OF MERCHANTABILITY AND OF FITNESS FOR A PARTICULAR PURPOSE** regarding any such used item except for the express warranties specifically described on the reverse side hereof, if any. An explanation of each warranty offered by Mustang is set forth below. **ONLY THE WARRANTY DESCRIBED ON THE REVERSE SIDE HEREOF WILL BE APPLICABLE TO THE SALE BY MUSTANG OF THE PRODUCTS DESCRIBED HEREIN.**

A. BONDED BUY — If the applicable warranty is "Bonded Buy", the product described on the reverse side hereof will be warranted against defective material or workmanship for a period of **60 days** from purchase date. No charge will be made for parts or labor if the defect occurs and Mustang is notified in writing during the **60 day** period from purchase date.

B. PREMIUM BUY — If the applicable warranty is "Premium Buy", the product described on the reverse side hereof will be warranted against defective material or workmanship for a period of **30 days** from purchase date. No charge will be made for parts or labor if the defect occurs and Mustang is notified in writing during the **30 day** period from purchase date.

C. CERTIFIED BUY — If the applicable warranty is "Certified Buy", the product described on the reverse side hereof will be warranted against defective material or workmanship for a period of **30 days** from purchase date. If defects do exist Mustang will pay **ONE-HALF** of cost for parts and labor if Mustang is notified in writing during the **30 day** period from purchase date.

D. BUY AND TRY — If the applicable warranty is "Buy and Try" and the product does not meet purchaser's satisfaction, it may be returned within three days of purchase for a full refund. **THERE ARE NO OTHER IMPLIED OR EXPRESS WARRANTIES.**

E. "AS IS" — If the applicable warranty is "As Is", no **IMPLIED OR EXPRESS WARRANTIES** of any kind whatsoever will be applicable to product purchased.

The parties agree that the Customer's **SOLE AND EXCLUSIVE REMEDY** against Mustang under **BONDED, PREMIUM or CERTIFIED BUYS** will be for the repair or replacement of defective parts as provided in the warranty or condition selected. Repair or Replacement shall be at Mustang's discretion and **AT MUSTANG'S REGULAR PLACE OF BUSINESS**, during normal business hours. Customer agrees that no other remedy (including but not limited to claims for **INCIDENTAL, SPECIAL OR CONSEQUENTIAL DAMAGES, FOR ANY CAUSE WHATSOEVER, or INJURY TO PERSONS OR PROPERTY, OR ANY OTHER CONSEQUENTIAL, ECONOMIC OR SPECIAL INCIDENTAL LOSS**) shall be available to him.

Customer acknowledges and agrees that this quotation contains all agreements between Customer and Mustang and they are hereby accepted by Customer. Customer further agrees and acknowledges that no verbal contracts, agreements or warranties other than what is written in this quotation have been received or given, and signature on this quotation by Customer acknowledges this fact.

3. Force Majeure. This quotation, when accepted by Customer, shall become a binding contract but Mustang's obligation to deliver shall be conditioned upon and subject to strikes, walkouts, accidents, fire, delays in manufacturer transportation, acts of God, and embargoes or Governmental action or any other causes beyond the control of Mustang whether the same as or different from the matters and things hereinabove specifically enumerated, and any of such causes shall absolutely absolve Mustang from any liability to Customer, under the terms hereof. Upon acceptance, Customer, shall be obligated to pay the purchase price applicable to the products reflected on the reverse side hereof in accordance with the terms hereof and of any other documents now, heretofore or hereafter executed to evidence such obligation.

4. Security Interest. If the product(s) is not paid for in full in cash at the time of delivery, Mustang will retain and Customer hereby grants to Mustang a security interest in such product(s) within the meaning of the Uniform Commercial Code together with all and any substitutions, additions, or accessions to such product(s), and in any and all proceeds from the sale, exchange or disposal thereof to secure payment of the purchase price of such product(s). Customer, prior to or after delivery, specifically agrees to enter into and execute a financing statement, or statements, and an additional security agreement setting forth the terms and conditions of the Agreement between the parties in relation to the security interest of Mustang. Customer further appoints Mustang as its attorney-in-fact to execute any such financing statement or security agreement in the place and stead of Customer. In the event Customer fails to execute any such financing statement or security agreement upon request by Mustang, the entire balance of the purchase price shall at Mustang's option become due and payable and Mustang shall have all remedies available to it provided for and set out in the Uniform Commercial Code. Customer also agrees to execute and deliver to Mustang any notes or other evidences of indebtedness that may be required by Mustang. However, any note taken herewith shall be evidence of Customer's obligation to pay the unpaid time balance only and is not to be considered or construed to be payment for the product(s). **LATE OR DEFERRED PAYMENT SHALL BEAR INTEREST AT THE HIGHEST CONTRACT RATE PERMITTED BY LAW.**

5. Shipment. Mustang's responsibility for shipment will cease upon delivery to a transportation company and any claims for shortages, delays or damages occurring thereafter shall be made by Customer directly to the transportation company. Any claims which Customer may be entitled to make against Mustang for shortages and shipments shall be made within fifteen (15) days after receipt of shipment.

6. Enforceability, Entire Agreement. Customer agrees that this quotation, upon acceptance by Customer, shall not be countermanded by him and that when it is accepted (and until the execution and delivery of the contract or contracts and note or notes required to consummate the sale of this above specified) it will, together with any security agreement, promissory note or other evidence of indebtedness executed by Customer subsequently hereto, constitute the entire agreement between the parties relative to this transaction. Customer further agrees that Mustang is not bound by any representations or agreements made by any agent or employee of Mustang relative to this transaction unless specifically embodied herein.

7. Indemnity. Customer further agrees to indemnify and save harmless Mustang from all loss, damage, expense and penalty arising from any action on account of any injury to person or property of any character whatsoever occasioned by the operation, handling or transportation of any of the product(s) covered by this quotation and while the product(s) is in the possession or under the custody and control of Customer.

8. Place of Payment, Venue. In consideration of the sale of the product(s) by Mustang, Customer agrees to pay Mustang for such product(s) at Mustang's principal office in Houston, Harris County, Texas.

9. Attorney's Fees. In the event any action either to collect payment or enforce the terms and provisions of this quotation becomes necessary, Customer agrees to pay reasonable attorney's fees to Mustang should this matter be placed in the hands of an attorney for collection.

10. Miscellaneous. This quotation shall be interpreted and construed in accordance with the laws of the State of Texas. Invalidity of any portion of this quotation shall not affect the validity or enforceability of the remainder of the terms and conditions hereof, and the parties hereby agree that this quotation shall be construed as if such invalid provision had not been inserted.

11. Termination of Quotation. This quotation shall terminate unless Mustang receives written acceptance hereof within the period set forth on the reverse side hereof. Such written acceptance must refer to the quotation number and date of this quotation.

12. Cancellation. In the event Seller consents in writing to cancellation, Buyer shall pay Seller, at Seller's option, the following as liquidated damages:

- Invoice price of all goods which have been identified to the contract, whether such goods have been delivered to Buyer or not.
- Actual costs incurred by Seller for goods not completed which are allocable to the balance of the contract, including the cost of discharging Seller's liabilities which are so applicable and the costs of materials on hand which were acquired or produced in connection with partially finished work and materials.
- A reasonable allowance for profit in connection with goods called for under the contract, but with respect to which production has not yet begun at the time of cancellation.
- Reasonable costs incurred by Seller, including accountants' and attorneys' fees, if any, in making any termination settlement hereunder.